

Expansion Tank Saddles

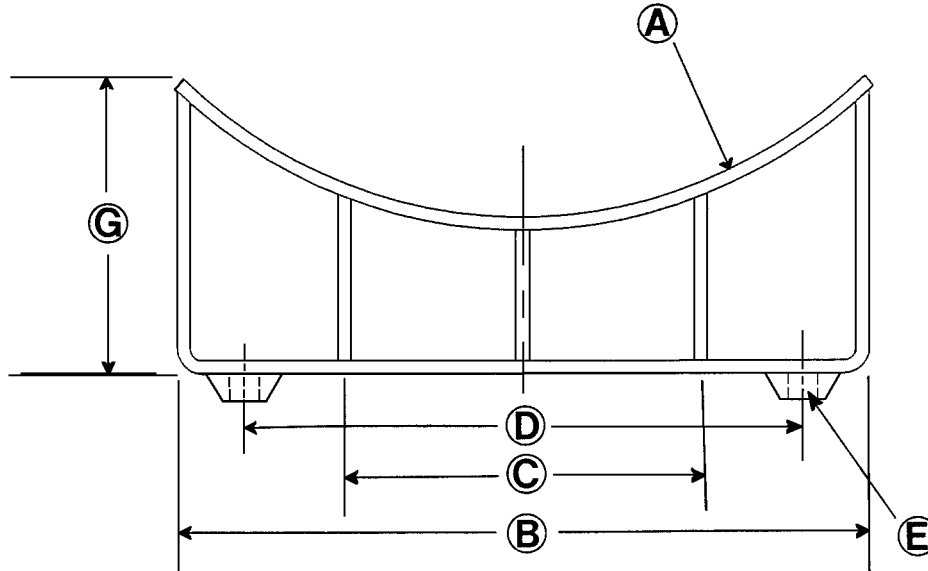

Dimensions (In Inches)

Tank Diameter	A	B	C	D	E	F	G
12"	6	10	N/A	7	1 1/2 NPT	3	6 5/32
14"	7	12	N/A	9	1 1/2 NPT	3	6 9/16
16"	8	14	N/A	11	1 1/2 NPT	3	7 1/4
20"	10	16	8	12	2 NPT	4	7 1/4
24"	12	18	9	14	2 NPT	4	7 7/16
30"	15	22	11	17	2 1/2 NPT	5	8 3/16
36"	18	28	13	22	2 1/2 NPT	5	8 15/16

JOB NAME _____
 LOCATION _____

 CONTRACTOR _____
 CONTRACTOR P.O. NO. _____

ITEMS	QUANTITY
_____	_____
_____	_____
_____	_____
_____	_____
_____	_____