

TDV-N/TSV-N Valve

Available in sizes 3" through 12" with ductile iron bodies and flanged connections. Standard features include:

- ENP (Electroless Nickel Plated) Plug & 304 Stainless Steel Clapper for enhanced performance in corrosive environments
- Trunnion supported plug
- Schrader valve metering connections
- Memory stop which avoids the need for resetting after shut-down
- Plug position indicator and calibrated scale for system balancing and flow regulation
- Spring loaded clapper allows the valve to be installed horizontally
- Dual O-ring stem seals
- Non-lubricated operation
- Bubble-tight shut-off

The unique quarter-turn TDV/TSV design offers backflow protection throughout a wide range of system balancing settings. Upon closing, the plug rotates to block the downstream port of the valve allowing pressure to equalize around clapper so that it closes with little resistance. Final closing is accomplished by the plug camming against the backside of the clapper. The most satisfactory closure is accomplished by turning the plug to a normal tight fit, then bumping the plug lightly.



Multi function benefits

- Flow regulator valve
- Positive shut-off valve
- Convenient connections for gauges
- Compact size reduces space requirements

Internal Spring-loaded Clapper

Valve Clappers are internally spring-loaded for a positive check.

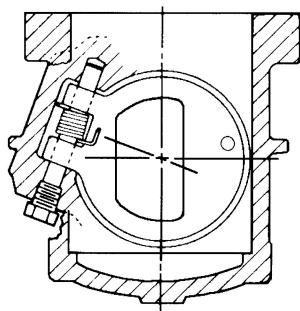

Sectional view looking upstream

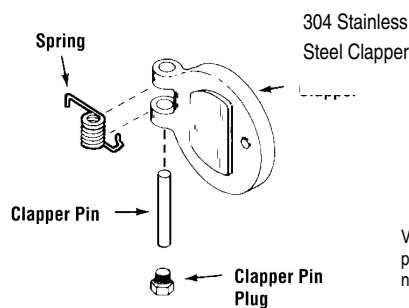

NOTE: One end of clapper pin is tapped for pin removal

Memory Stop

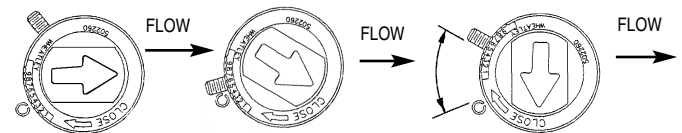
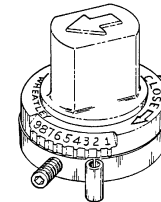

Valve is shown in open position. Memory Stop has not been set.

Valve Plug is rotated to selected balance position. Memory stop is rotated until it intercepts the stop on cover. Tighten lock screw on memory stop.

Valve plug may be closed and re-opened to same balance position.

JOB NAME _____
LOCATION _____
CONTRACTOR _____
CONTRACTOR P.O. NO. _____

ITEMS	QUANTITY
_____	_____
_____	_____
_____	_____
_____	_____
_____	_____

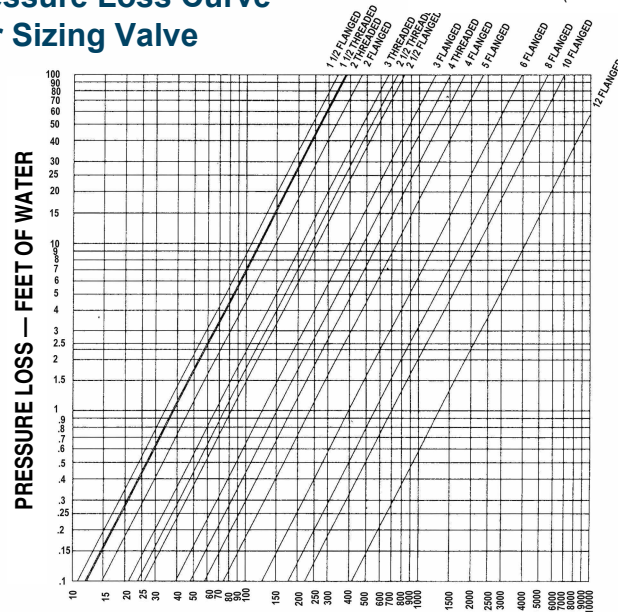
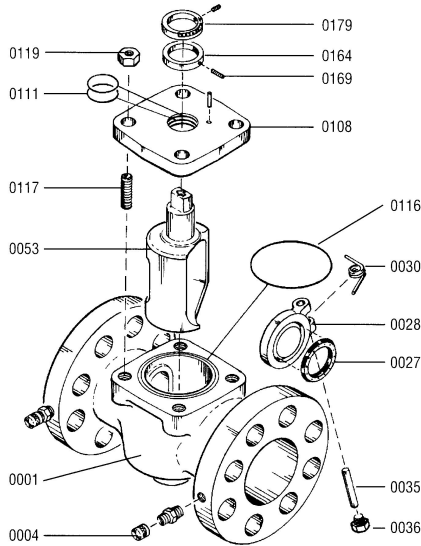

FLOW RATE — GPM WATER AT 70°F
 *For individual balancing flow charts, please consult factory

Bill of Materials:

Item Number	Description	Qty	Material
0001	Body	1	Ductile Iron (60-40-18)
0004	Metering connector	2	Brass
0027	Clapper seal	1	Buna
0028	Clapper	1	304 Stainless Steel
0030	Spring	1	Stainless Steel
0035	Clapper Pin	1	Stainless Steel
0036	Pipe Plug	1	Steel
0053	Plug	1	DI(60-40-18) ENP(2 mil)
0108	Cover	1	Ductile Iron (60-40-18)
0111	O-ring	2	Buna
0116	O-ring	1	Buna
0117	Cover Stud	4	Steel
0119	Nut	4	Steel
0164	Memory Stop Ring	1	Steel
0169	Set Screw	1	Steel
0179	Indication Rng	1	Steel

**Cast Iron
 Flanged Ends
 Bolted Covers**

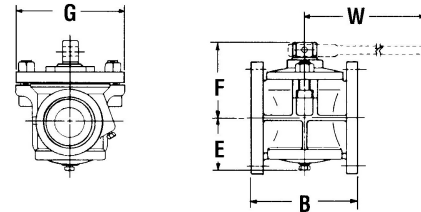

Wrench Operated Class—175 lbs. WOG

Description	Nominal Pipe Size										
	1 1/2	2	2 1/2	3	4	5	6	8	10	12	
End-to-End, Threaded	A	Not Available See Standard TDV/TSV Valve									
Face-to-Face, Flanged	B										
Center of port to top of valve	E										
Center of port to top of valve	F										
Extreme width of body	G										
Wrench extension	W										
Weight (approx.) lb., Threaded	-	-	-	-	-	-	-	-	-	-	
Weight (approx.) lb., Flanged	-	42	64	95	122	165	270	385			

American Wheatley HVAC reserves the right to change materials without notice. illustration: 10", 175wp., flanged end. HVAC TDV/TSV™

* All flange holes tapped size 4, 6 and 8 inch valves.
 Flange dimensions per ANSI standard B16. 1, Class 125.
 NPT line pipe threads optional wrench available.

Dimensions are subject to change without notice, please confirm actual dimensions with factory at time of order.

Installation:

- Mount 3" through 12" valves in a vertical up or horizontal position with flow in the direction of the flow arrow which is cast on the side of each valve.
- Install valve in a location which allows easy access to operating wrench and flow meter connections.
- Install with the equivalent of at least 10 diameters of straight pipe, sized to the TDV/TSV valve, upstream of the valve and the equivalent of at least 5 diameters of pipe downstream of the TDV/TSV valve.
- Once a flow rate has been set, adjust the memory stop located on the stem of the TDV/TSV valve (see memory stop illustration on tag attached to valve for adjustment instructions). The memory stop allows the valve to be closed and re-opened to the same balance position.

Flow Meter Operation

- Remove caps from the metering connections at the HI and LO pressure taps.
- Connect the high pressure hose (red) of the pressure gage to the HI pressure connection on the TDV/TSV valve and the low pressure hose (blue) to the LO pressure connection. Note: Hose ends require valve depressors to be connected. If valve depressor is not visible in hose end check opposite end of hose. Metering connection valves are opened automatically as the hose end is screwed on.
- Prepare the pressure gauge as per instructions in the gauge kit.
- The flow can be determined by reading the pressure indicated at the gauge, noting the valve opening from the plug position indicator and calibrated plate and transferring this data to a flow chart.
- When flow readings are complete, follow directions supplied with the pressure gauge.
- Replace metal caps on the metering connectors of the TDV/TSV valve.